



*The proof is
in the product.*

August 2013

Warequip P2GO Cagemate Instruction Manual



*Please ensure you are familiar with the correct operation
of the Warequip P2GO CAGEMATE*

Introduction

Thank you for choosing the Warequip P2GO Cagemate.

It is important to read and follow all instructions and safety information contained in this Operation Manual prior to use.

Warequip hopes the Cagemate will make your job safer, easier and more fun. The Cagemate can boost the productivity in your organization and reduce injuries caused by repetitive pushing and pulling a manual trolley. Therefore, you will create a happy and safe working environment and minimize the skyrocketing workers compensation insurance costs.

The Cagemate is a battery powered mobile platform truck used for moving materials, parts or machinery from one location to another without having to manually carry the load or push a wheeled trolley. These heavy push or pull trolley applications can occur anywhere, a dock at a marina, to distributing the company coffee machine around the plant, garage or workshop.

If these trolleys need constant pushing or pulling from one location to another and cause fatigue to the employee moving the load, then it is the perfect application for our battery powered product.

Operation

1. Turn ON Power

Insert the power key into the switch lock and turn clockwise to the “ON” position. All the battery display lights should be on indicating the batteries are full and ready to work.

2. Check the Status

The status light should be on steadily if the electric and driving systems are OK. If it flashes, check the clutch engagement first located near the drive wheels.

3. Forward Motion

Start you P2GO Cagemate. Stand behind the tiller and hold the ‘bull-horns’ with two hands. Look straight ahead. Press the upward throttle lever with your thumbs slowly to start moving forward. The speed should increase as you press more.

4. Stop

Slowly releasing your thumbs from the throttle lever will reduce the speed and stop the cart.

5. Emergency Stop

Just simply release your thumbs quickly. The Cagemate should stop within 4.5 feet at full forward speed.

6. Reverse Motion

Press the downward throttle lever with your thumbs slowly to start moving in reverse.

7. Forward Steering

Look straight ahead. When you need to turn right, you turn the ‘Caster’ to the left. Vice a Versa for the left turn.

8. Reverse Steering

The operation is the opposite to forward steering.

9. Move Manually (Free Wheeling)

Manual: You push or pull the Cagemate by disengaging the clutch in the transaxle.

Power: You can push or pull the Cagemate by pressing the yellow free-wheel button by your right hand finger and operating by your left hand.

10. Cage Option

If your unit is fitted with a cage you can remove the sides by simply lifting them off. Pull directly upwards. The ends are also removable. To refit reverse the operation.

WARNING

Before you operate, practice in an open area for **at least one hour** to get familiar with the Cagemate and gain the operation skills. The brake may not be effective when engaged on inclines greater than the grade with allowed load. Be alert!

EMERGENCY STOP

In case of out-of-control, turn the power off or pull safety button immediately!

SAFETY INSTRUCTIONS

Warequip disclaims all responsibility for any personal injury or property damage which may occur as a result of improper or unsafe use of its products. The following guidelines are intended to assist you in the safe operation of your P2GO Cagemate. Should you have any questions about the correct operation of your P2GO Cagemate, please contact Warequip for assistance.

Your Cagemate can negotiate grass, gravel, dirt and sand surfaces as well as hard paved or carpeted surfaces. However, extra caution should be taken when operating your unit on uneven surfaces other than flat surfaces.

Electromagnetic Interference (EMI)

Electrically powered equipment may be susceptible to Electromagnetic Interference (EMI). Sources such as Radio Stations, TV Stations, Amateur Radio Transmitters, Two Way Radios and Cellular Phones all emit electromagnetic energy (EM). It is highly unlikely but in extreme cases where the intensity of EM is very high it may cause the powered equipment to release its brakes or move by itself. Powered equipment has a certain immunity level which in most cases is adequate. If you feel EMI may be a risk then you should conduct a site specific test and risk assessment to ensure the EM is within the products immunity level.

If you notice any unintentional movement or brake release we recommend turning the unit off immediately taking note of any high powered communications device in the area.

In Summary

DO NOT try to climb sharp curbs

DO NOT drive over obstacles exceeding 5cm in height

DO NOT make an abrupt change at high speed or while travelling on an incline

DO NOT attempt to make a fast turn on flat surfaces

DO NOT climb inclines greater than 8 degrees or a rise of 2 meters in 10 meters

DO NOT back onto uneven surfaces or inclines

DO NOT attempt to operate your unit in a stalled condition, such as travelling up too steep an incline. This may cause the circuit breaker or thermal cut out to trip, rendering your unit temporarily immobile.

DO NOT operate your unit when the red battery indicator light is flashing

BE AWARE of nearby transmitters, such as radio or TV stations and hand-held or mobile two-way radios and try to avoid coming close to them.

Battery Charging

To ensure the best performance and maximum battery life, we recommend frequent battery charging. Your P2GO Cagemate comes with an on-board battery charger for your ease and convenience.

The console battery display makes charging simple and easy.

Follow these steps for battery charging.

1). The console battery display:

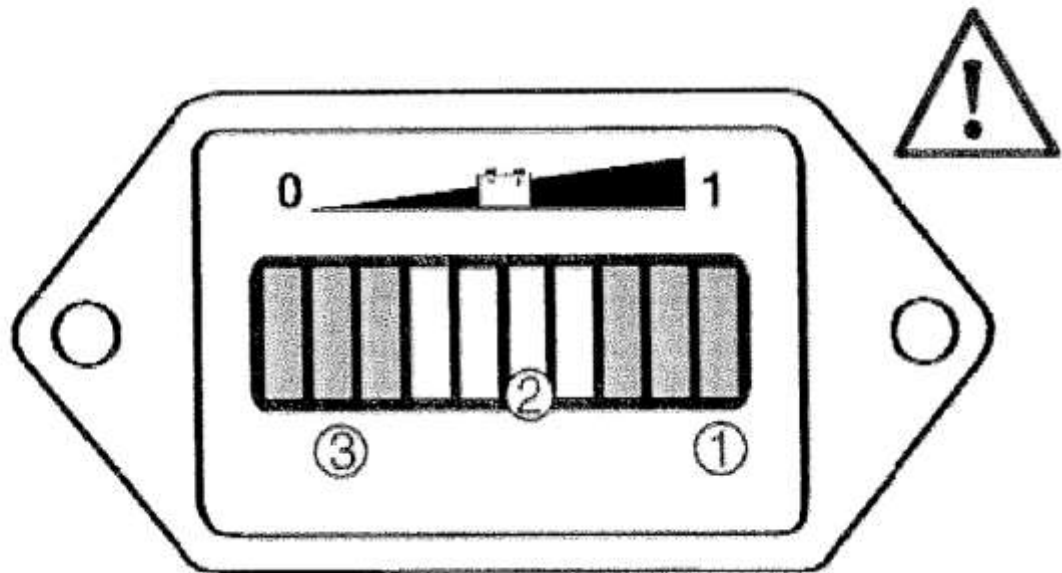

Only when the battery is properly charged is the right-most green LED lit. As the battery's state-of-charge decreases, successive LEDs light up, only one on at a time. The 3rd from left red LED flashes indicating 'energy reserve' (70% depth of discharge). The 3 left-most LEDs alternately flash, indicating 'empty' (80% depth of discharge).

2. On a level dry surface, turn off the power key and plug the AC cord into the charger socket located on the fibre-glass compartment. Plug the other end of the AC cord into a grounded wall outlet.

3. Charge the battery for 6-8 hours depending on the usage before charging. Disconnect the AC cord, insert key into tiller and check if all green lights are on.

4. There is no possible way to overcharge the battery since the charging voltage in the floating stage is set constant. In general, you may start charging after work and disconnect the next morning.

WARNING

You must turn OFF power before charging. Otherwise it may damage the electric circuit.

Maintenance Schedule

In order to obtain the best performance and last its service life, please maintain your unit according to the following schedule and instructions.

DAILY

1. Test brake effectiveness before you drive
2. Recharge batteries fully every night

WEEKLY

1. Check tyre pressure – Pressure should be 40-50 psi
2. Check and tighten the throttle screw

MONTHLY

1. Check battery condition. Clean battery terminals if necessary
2. Check all electrical wire connectors to eliminate loose connections
3. Tighten all exposed screws and nuts
4. Check wheel bearings by spinning tyres and checking for free rotation

Throttle Adjustment

1. Release the clutch level, thus the motor can rotate freely
2. Note on the throttle control potentiometer, when the control lever is swinging, how the mount plate retain one end of the spring while the control bracket pulls the other end of the spring in the direction of rotation. As the lever rotates in the opposite direction, the other spring end is pulled in the opposite direction.
3. With key in and speed setting at low, rotate the throttle lever until you just hear the brake release click and motor starts running. Notice the angle rotated between the lever and the P2GO Cagemate.
4. Rotate the throttle lever in the opposite direction till just brake release clicks, notice the angle rotated between the lever and P2GO Cagemate in this direction.
5. If the angles are not identical, loosen control bracket screws, rotate potentiometer shaft and few degrees by using a flat screwdriver and re-tighten it.
6. Repeat until the reverse, neutral and forward are in proper ranges.
7. Make sure throttle control lever is parallel to tiller handle. If the lever is not parallel, full range rotation in one direction will not be possible, resulting in loss of speed in that direction.

LIMITED WARRANTY

This warranty is extended only to original consumer purchasers of the Warequip P2GO Turnmate either from the authorized retailers or representatives.

Warequip warrants that the products manufactured by them to be free from defects in materials and workmanship for a period of 1 year from the date of purchase for business use. If, within such warrant period, any such products shall be proven to Warequip's satisfaction to be defective, such product shall be repaired or replaced at Warequip's option. This warranty does not include any shipping charges incurred in replacement part installation or repair of such product. Warequip's sole obligation and your exclusive remedy under this warranty shall be limited to such repair and/or replacement.

For warranty service please contact Warequip on 1800 337 711.

DO NOT RETURN PRODUCTS TO US WITHOUT OUR PRIOR WRITTEN CONCENT.

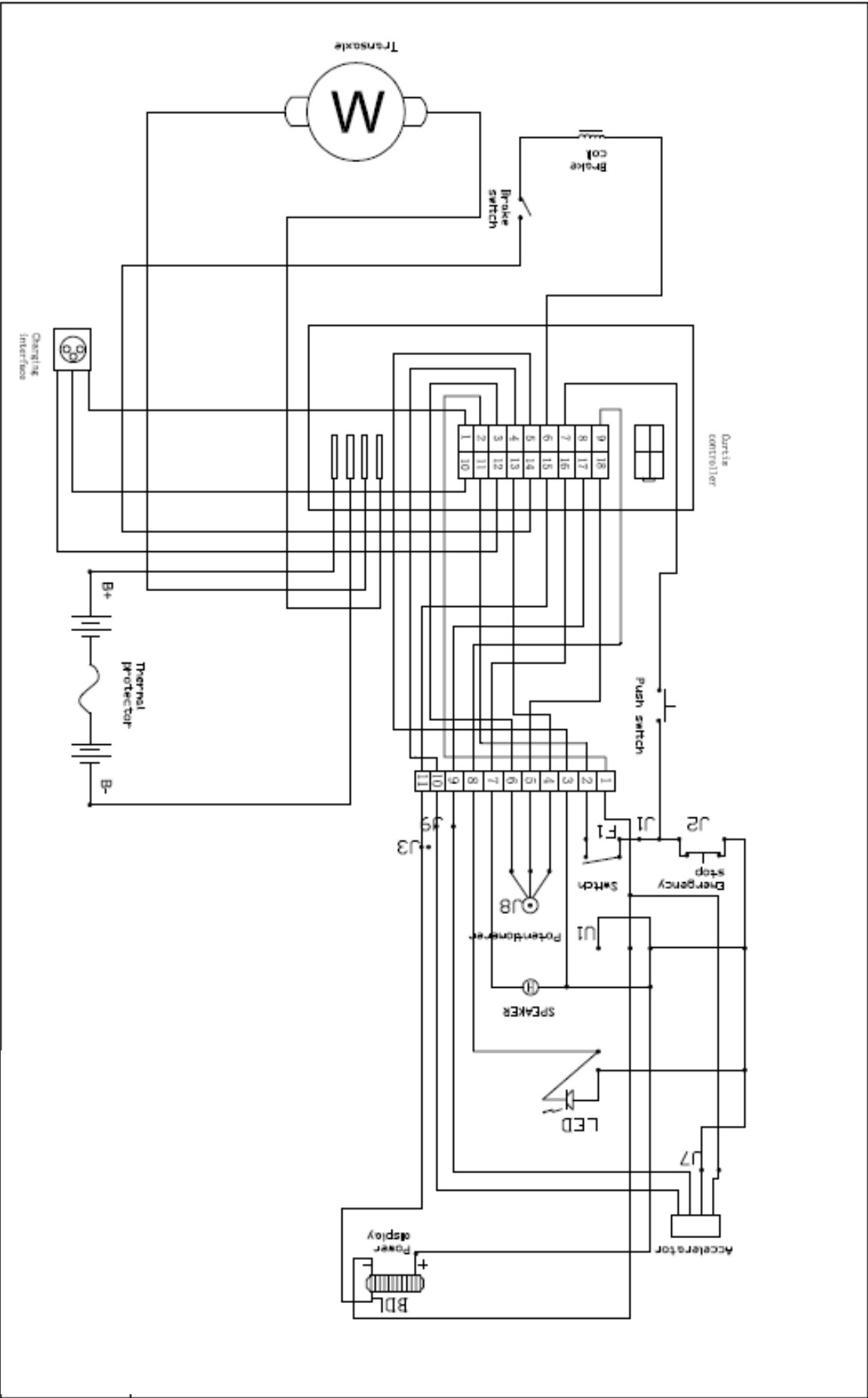

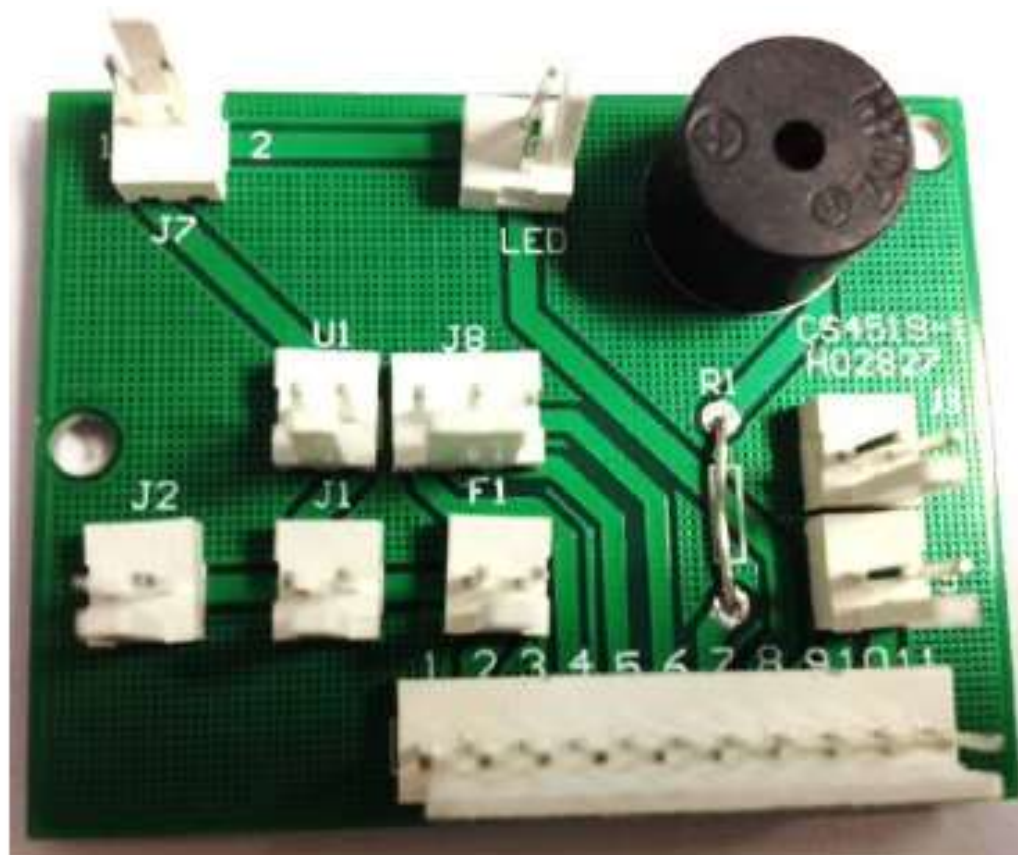

Code	Item	Code	Item
J7	Throttle Module (<i>orange/green line</i>)	J1	Brake Release Switch
LED	Red LED Light	F1	Key Switch
U1	Battery Status Indicator (<i>double line</i>)	J3	Battery Status Indicator (<i>single line</i>)
J8	Speed Dial	J9	Throttle Module (<i>black/white line</i>)
J2	Emergency Stop Switch	11 PIN	Main Wiring Loom

Table 2 STATUS LED FAULT CODES

LED CODES		EXPLANATION
<i>LED off</i>	■	no power or defective controller controller operational; no faults
<i>solid on</i>	□	
1,1	□ □	thermal cutback fault
1,2	□ □□	throttle fault
1,3	□ □□□	speed limit pot fault
1,4	□ □□□□	undervoltage fault
1,5	□ □□□□□	overvoltage fault
2,1	□□ □	main contactor driver Off fault
2,3	□□ □□	main contactor fault
2,4	□□ □□□	main contactor driver On fault
* 3,1	□□□ □	HPD fault present for >10 seconds
3,2	□□□ □□	brake On fault
3,3	□□□ □□□	precharge fault
3,4	□□□ □□□□	brake Off fault
3,5	□□□ □□□□□	HPD (High Pedal Disable) fault
* 4,1	□□□□ □	current sense fault
* 4,2	□□□□ □□	motor voltage fault (hardware failsafe)
* † 4,3	□□□□ □□□	EEPROM fault
* 4,4	□□□□ □□□□	power section fault

* = Must cycle keyswitch to clear.

† = Must use programmer to clear, as follows: select Program Menu, alter data value of any parameter, cycle keyswitch.

NOTE: Only one fault is indicated at a time, and faults are not queued up.

Table 3 TROUBLESHOOTING CHART

LED CODE	PROGRAMMER LCD DISPLAY	EXPLANATION	POSSIBLE CAUSE
1,1	THERMAL CUTBACK	over-/under-temperature cutback	1. Temperature >92°C or < -25°C. 2. Excessive load on vehicle. 3. Operation in extreme environments. 4. Electromagnetic brake not releasing.
1,2	THROTTLE FAULT 1	throttle fault	1. Throttle input wire open or shorted. 2. Throttle pot defective. 3. Wrong throttle type selected.
1,3	SPD LIMIT POT FAULT	speed limit pot fault	1. Speed limit pot wire(s) broken or shorted. 2. Broken speed limit pot.
1,4	LOW BATTERY VOLTAGE	battery voltage too low	1. Battery voltage <17 volts. 2. Bad connection at battery or controller.
1,5	OVERVOLTAGE	battery voltage too high	1. Battery voltage >36 volts. 2. Vehicle operating with charger attached. 3. Intermittent battery connection.
2,1	MAIN OFF FAULT	main contactor driver Off fault	1. Main contactor driver failed open.
2,3	MAIN CONT FLTS	main contactor fault	1. Main contactor welded or stuck open. 2. Main contactor driver fault. 3. Brake coil resistance too high.
2,4	MAIN ON FAULT	main contactor driver On fault	1. Main contactor driver failed closed.
3,1	PROC/WIRING FAULT	HPD fault present for >10 sec.	1. Misadjusted throttle. 2. Broken throttle pot or throttle mechanism.
3,2	BRAKE ON FAULT	brake On fault	1. Electromagnetic brake driver shorted. 2. Electromagnetic brake coil open.
3,3	PRECHARGE FAULT	precharge fault	1. Low battery voltage. 2. KSI and throttle turned on at same time.
3,4	BRAKE OFF FAULT	brake Off fault	1. Electromagnetic brake driver open. 2. Electromagnetic brake coil shorted.
3,5	HPD	HPD (High Pedal Disable) fault	1. Improper sequence of throttle and KSI, push, or inhibit inputs. 2. Misadjusted throttle pot.
4,1	CURRENT SENSE FAULT	current sense fault	1. Short in motor or in motor wiring. 2. Controller failure. *
4,2	HW FAILSAFE	motor voltage fault (hardware failsafe)	1. Motor voltage does not correspond to throttle request. 2. Short in motor or in motor wiring. 3. Controller failure. *
4,3	EEPROM FAULT	EEPROM fault	1. EEPROM failure or fault.
4,4	POWER SECTION FAULT	power section fault	1. EEPROM failure or fault. 2. Short in motor or in motor wiring. 3. Controller failure. *

P2GO Trolleys Spare Parts

CM- Cagemate / LM- Liftmate / TM- Turnmate / MC- Maids Cart

Part No.	Description
P2GOT001	Accelerator/Throttle Module - CM, LM, TM, MC
P2GOT002	Red Speed Control Push Lever (Set of 2)- CM, LM, TM, MC
P2GOT003	Control Box with Dial* - CM, TM, MC
P2GOT004	Control Box (old style) On/Off Only - CM
P2GOT005	Control Box with Up/Down Buttons* - LM
P2GOT006	Battery Status Indicator - CM, LM, TM, MC
P2GOT007	Key Switch - CM, LM, TM, MC
P2GOT008	Red Emergency Stop Plastic Button Cover- CM, LM, TM, MC
P2GOT009	Green Emergency Stop Switch (Behind Red Button) - CM, LM, TM, MC
P2GOT010	Yellow Brake Release Switch - CM, LM, TM, MC
P2GOT011	Red LED Status Indicator - CM, LM, TM, MC
P2GOT012	Blue Swivel Castor - CM, LM, TM,
P2GOT013	Pneumatic Wheel - CM, LM, TM, MC
P2GOT014	Battery Charger Outlet - CM, LM, TM, MC
P2GOT015	Battery Charger Box Release Nut - CM, LM, TM, MC
P2GOT016	Battery Charger Release Nut - LM
P2GOT017	Battery Charger - CM, LM, TM, MC
P2GOT018	Handle Grip - CM, LM, TM, MC
P2GOT019	Solenoid - LM
P2GOT020	Black Relay - LM
P2GOT021	Black Circuit Breaker - LM
P2GOT022	Green Microswitch - LM
P2GOT023	Lift Cylinder (new style) - LM
P2GOT024	Lift Cylinder old style) - LM
P2GOT025	Hose Kit (new style)- LM
P2GOT026	Hose Kit (old style) - LM
P2GOT027	11 Pin Interface / Circuit Board In Control Box - CM, LM, TM, MC
P2GOT028	Large Circuit Board (14 screw, 4 relay)
P2GOT029	Main Wiring Loom - CM, LM, TM, MC
P2GOT030	Power Pack - CM, LM, TM, MC
P2GOT031	Transaxle - CM, LM, TM, MC
P2GOT032	Adhesive Rubber Bumper Strip For Base - CM, LM, TM, MC

**Control boxes include switches and wiring but do not include accelerator module, circuit board or emergency button*

P2GO Trolley

Preventative Maintenance Schedule

Task	Daily	Weekly	Monthly
Test brake effectiveness before you drive	●		
Recharge batteries fully every night	●		
Check tyre pressure - Correct pressure 40 – 50 PSI		●	
Check and tighten the throttle screw			
Check battery condition and clean battery terminals If necessary		●	
Check all electrical wire connectors to eliminate loose connections			●
Tighten all exposed screws and nuts			●
Check wheel bearings by spinning tyres and checking for free rotation			●